

# INSTALLATION GUIDE

# Tuffloor™



## WHY YOU SHOULD USE TUFFLOOR

Tuffloor is a steel floor framing system designed for strength and ease of installation. The system is ideal for domestic house construction and extensions, but can also be used for commercial and industrial situations.

## BEFORE YOU START

Carefully read these instructions. If you do not have all the necessary tools or information, contact Stratco for advice. Before starting, lay out all the components and check them against the delivery docket. The components identify each key part required in the construction, and the detailed diagrams indicate their locations. Double check all dimensions, levels and bolting locations before cutting, screwing or bolting structural members.

Before starting the flooring installation, the sub floor structure should be fully erected. Any concrete or masonry footings will need to be suitably cured before starting, to prevent any movement during the installation.

## TOOLS AND HARDWARE REQUIRED

- Level
- Square
- String Line
- Tape Measure
- Hacksaw
- Metal Cutting Saw
- Locking Grips
- Spanners and Sockets
- Screw Gun or Drill with Hex Bit
- Drill with 12mm and 14mm Bits

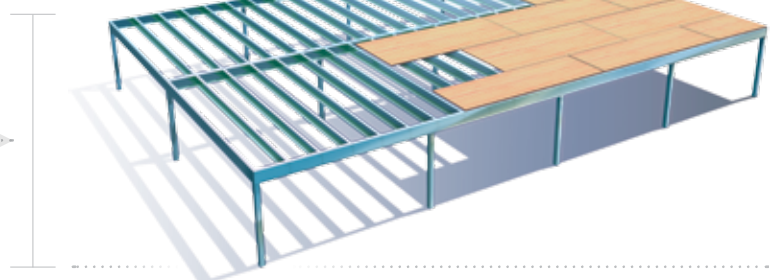

# COMPONENTS

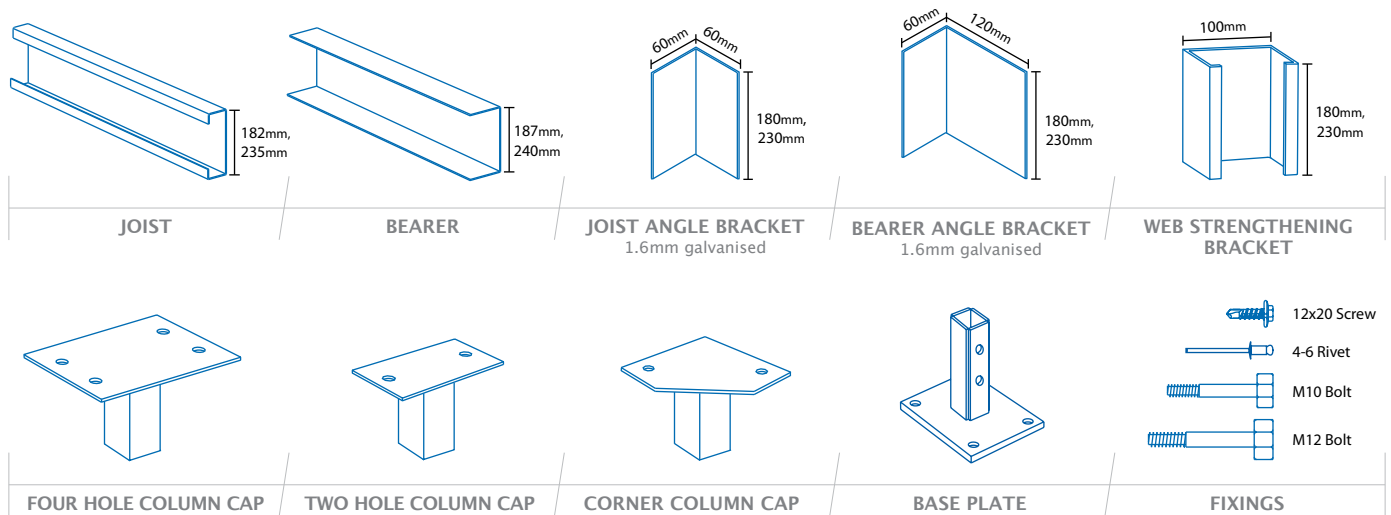

# SUPPORT

If column caps are used in conjunction with SHS columns, it is important that the correct column caps are used. They should not be bolted to the columns initially as minor levelling adjustments may need to be performed after positioning the bearers. If other support methods are used, they should be prepared ready for the installation of the bearers. Masonry and concrete stumps should include M12 starter rods for fixing to the bearers, as shown in figure 3.1.



# POSITION BEARERS

The bearers can now be positioned, and drill holes marked. Where column caps are used, the bearers will need to be fixed down using two M10 bolts per cap, or two 12x20mm screws per side as shown in figure 1.0. The column cap has pre-drilled holes to assist with the positioning of holes in the bearers. Once all holes are marked the holes can be drilled and the bearers placed into position.

Bolt holes need a diameter 2mm larger than that of the bolt, to assist with positioning the bearers. So for M10 bolts use a 12mm drill bit and for M12 bolts use a 14mm drill bit.

A web strengthening bracket will need to be installed above any concentrated load supports, such as column caps. The brackets need to be positioned to be flush with the base of the bearer. 235mm deep sections will need to be fixed using eight 12x20mm screws, whereas for 182mm deep sections only six 12x20mm screws are required, as shown in figure 1.0. Only one web strengthening bracket is required on back to back bearers passing over a support. If a web strengthening bracket cannot be positioned due to an interfering joist, the joist will need to be fixed to the bearer using an angle bracket.

Bearers meeting over a support need to be joined using a web strengthening bracket as shown in figure 1.1. Bearers that meet at a corner or internally will need to be fixed to each other using a bearer angle bracket as shown in figure 1.3. The bracket will need to be positioned inside, and flush with the bottom of the bearers. The bracket will need to be fixed using four 12x20mm screws per bearer. For a cleaner finish the screws should be installed from the outside.

Back to back bearers should also be fixed together at this stage using three 12x20mm screws at 50mm centres in the approximate position of each joist, as shown in figure 1.2.

Once the floor is level the bearers can be fixed to the support. When using column caps, fix them to the columns using one M12 bolt or eight 12x20mm screws per side, as indicated in figure 1.0. Column caps can be offset a maximum of 30mm from the top of the columns.

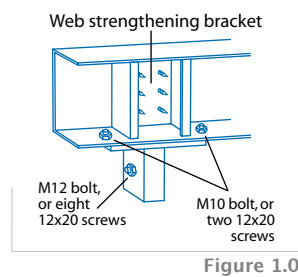

Figure 1.0

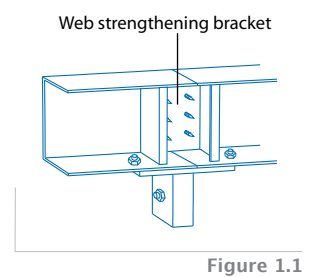

Figure 1.1

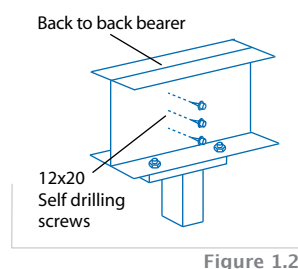

Figure 1.2

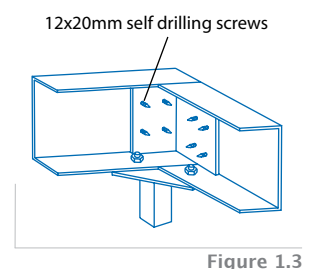

Figure 1.3

## INSTALL JOISTS

The joists should be sorted and placed near the bearers into which they will be positioned, making sure that the correct joist size is being used. The joists can now be rotated into position, as shown in figure 2.0. The clearance between the end of the joist and web of the bearer should be less than 10mm. It is best to start laying the joists from one end. It is important to ensure the correct spacing is used. Refer to your design specifications for the exact spacing. The short spacing should be left to last as this will minimize the amount of cutting required when installing the floor panels. The serviceability of the floor can be slightly increased by rotating alternate joists 180 degrees.

For joists not supporting load bearing walls fix the joist using one 12x20mm screw through the bottom flanges of the web and joist. This can be seen in figure 2.1. A flooring screw will need to be positioned to join the top webs later when the sheeting is installed, otherwise a size 4-6 steel rivet should be installed through the top flanges.

If a joist is supporting a load bearing wall, is positioned such that it will interfere with a web strengthening bracket, is not of the same depth as the bearer, or does not meet the bearer at right angles, an angle bracket will need to be used to fix the joist. The bracket should be positioned to be flush with the lower flange of the joist and be fixed using six 12x20mm screws at 40mm centres as shown in figure 2.2. For angled joists, the web will need to be positioned to be flush with the web of the bearer.

If the joists are to be welded to the bearers, three 3x30mm fillet welds should be used as shown in figure 2.3.

Floor joists longer than 3000mm need to be braced using a ceiling batten, or similar, installed along the midspan. This is to prevent them from twisting while installing the overlying floor sheets, as shown in figure 2.4. The bracing can be removed once the floor panels have been installed.

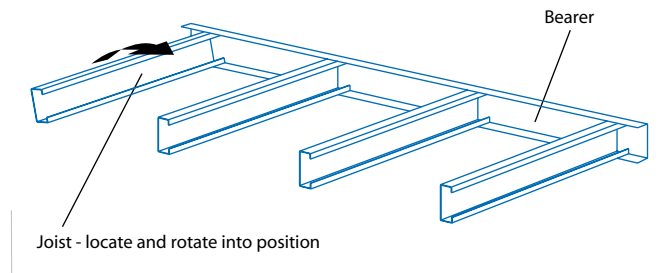

Figure 2.0

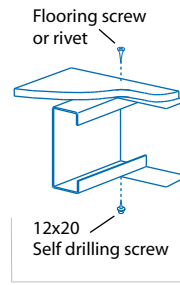

Figure 2.1

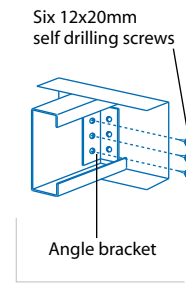

Figure 2.2

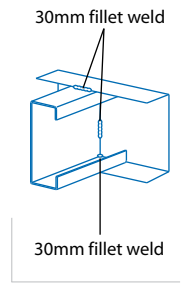

Figure 2.3

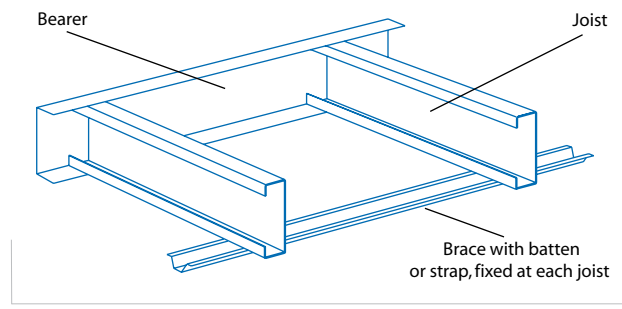

Figure 2.4

## OTHER CONNECTIONS

Where steel columns are used which pass through the floor, the bearers and joists can be fixed to the column using a joist angle bracket. For 182mm deep sections, five 12x20mm screws per side are required, 235mm deep sections, six 12x20mm screws are required, as shown in figure 3.0. In both cases the screws can be replaced with two M10 bolts. For other fixings an independent engineer should be consulted.

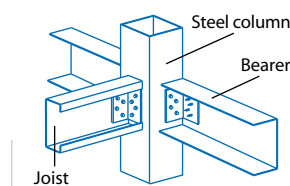

Figure 3.0

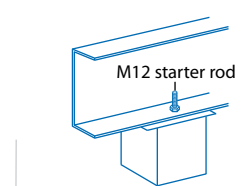

Figure 3.1

## WET AREAS

For wet areas where 182mm joists are used in conjunction with 235mm deep bearers, joist risers may need to be used to raise the level of the joists so that they are level with the bearers. The risers need to be positioned on the joist and flush with the web of a bearer, as shown in figure 4.0. The risers are to be fixed to the joists using 12x20mm screws at a maximum spacing of 250mm and no more than 50mm from the ends. Bearers can also be offset by up to 50mm as shown in figure 4.1 and fixed using three 12x20mm screws at each joist. Only the higher bearer needs to be supported.

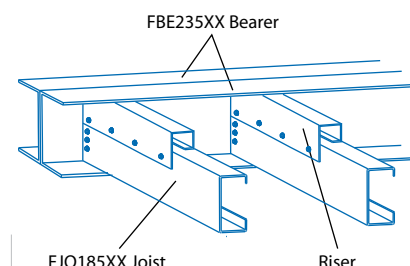

Figure 4.0

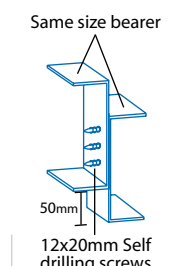

Figure 4.1

## SERVICE HOLES

Once the joists and bearers are positioned the location of service holes should be marked and drilled. Care should be taken to ensure that the holes are positioned correctly, see figure 5.0 and the table below. For brass or copper piping, rubber grommets will need to be installed.

Member Size	Maximum Hole Diameter	Minimum Support and End Distance
FBE182XX FJO182XX	90mm	370mm
FBE235XX FJO233XX	115mm	470mm

The minimum spacing between holes is three times the diameter of the holes.

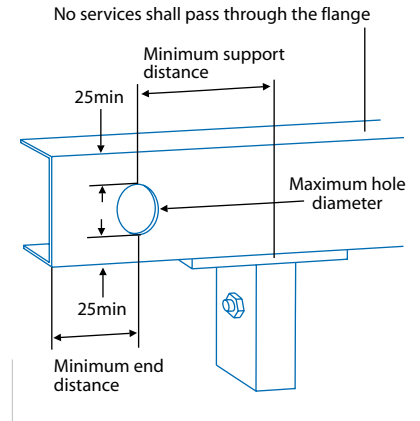

Figure 5.0

### CONTACT

1300 165 165

## INSTALL FLOORING

The following procedure is a general fixing method for particle board flooring. It is recommended that more specific fixing information be obtained from the floor panel manufacturer. It is recommended that CCA treated timber floor lining is not used with Tuffloor flooring as it may promote corrosion of the steel.

Floor sheets need to be installed perpendicular to the joists, starting at one corner and working towards the other corner. The end of each sheet will need to be placed over a joist. Sheets should be offset to keep a uniform stiffness over the floor. They should be fixed down as they are placed. It is recommended that an epoxy glue is used in conjunction with the screws.



## WALL FRAMING

Wall framing should be installed in accordance with the manufacturer's specifications for fixing to steel framed floors. Load bearing walls will need to be fixed through the floor lining into the bearer or joist, as shown in figure 6.0. Non load bearing walls need only be fixed to the floor lining.

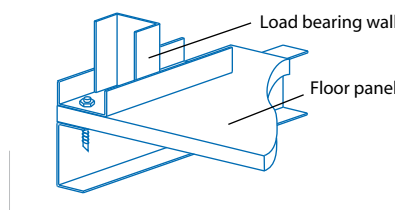

Figure 6.0

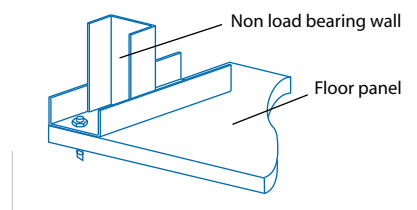

Figure 6.1

## MAINTENANCE REQUIREMENTS

Whilst all sections of the Stratco Steel Flooring System are galvanised to minimise corrosion, adequate ventilation should be provided where the system is subjected to humid conditions, e.g. close to the ground.

If joists are used externally, especially in corrosive environments such as coastal or industrial areas, paint protection is recommended. The floor frame will need to be electrically grounded. Refer to a qualified electrician for more information.

It is recommended that this brochure is read with the "Selection, Use and Maintenance" brochure.